

PETRA SEATS



Since 1937

100% made in ITALY





Standard Features

- Waterfalled seat insert provides more comfort, insert change out is quick, easy, and accomplished in seconds
- Contemporary design and colors to help create a relaxed and aesthetically pleasing environment
- Each seat is individually molded to give each passenger their own space. Also, the 560mm back height provides the back support needed for longer trips
- Improved hip to knee room compared to other transit seats
- Also available with tip up seats or foldaway style

Optional Features

- Different colors grab rails; Also available with antimicrobial treatment
- Heavy duty hand holds
- Several shell colors available (MOQ to be defined)
- Plain shell (low cost, durable), Padded inserts, or Padded AV (Anti Vandal)
- Available with a choice of inserts and vandal resistant options

PETRA 22



Components

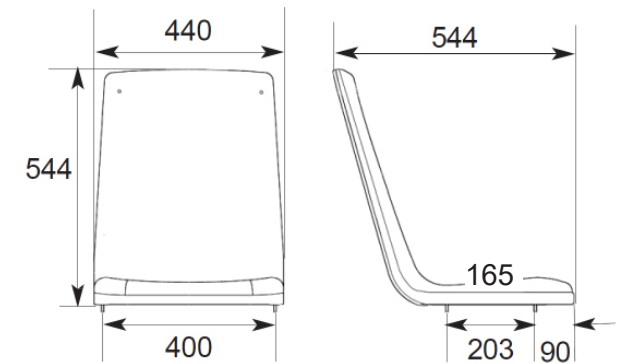

PETRA 219



Components

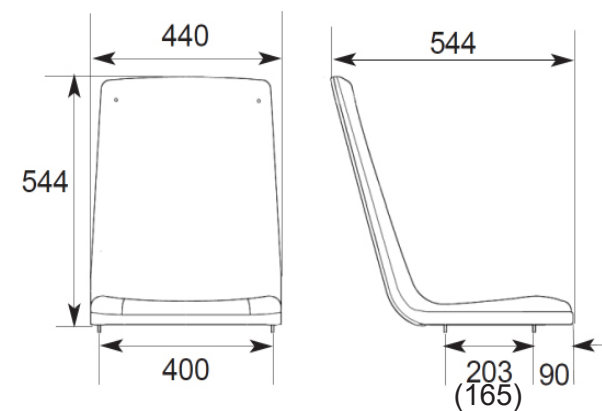

PETRA 400



Components

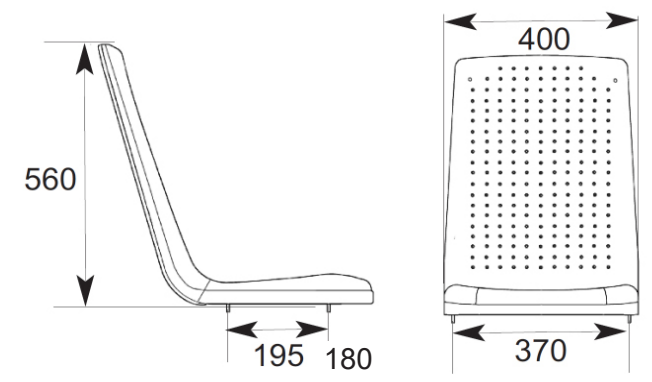

RUSPA

INNOVATION MANUFACTURING

Fondata nel 1937, Ruspa Officine è un 'azienda indipendente che non controlla e non è controllata da altre imprese.

Nel corso degli anni, ha sviluppato il proprio core business progettando e producendo equipaggiamenti speciali e componenti per il settore dei veicoli commerciali (trasporto di merci e persone).

Founded in 1937, Ruspa Officine is an independent company that does not control and is not controlled by other companies.

Over the years, it has developed its core business by designing and manufacturing special equipment and components for the commercial vehicle sector (transport of goods and people).

